

Job Name:		Location:	
Purchaser:		Submitted By:	
Submitted To:		Engineer:	
Date:		Application:	

Reference Approval Construction



Basic product info.

IDU Model Number	MSZ-FX18NL
ODU Model Number	MUZ-FX18NLHZ2
AHRI Certificate	216798018

Performance: Cooling at 95F (35C)

Cooling 95F Maximum Capacity	21500	Btu/h
Cooling 95F Rated Capacity	17200	Btu/h
Cooling 95F Minimum Capacity	3700	Btu/h
Cooling Maximum Power Input	2360	W
Cooling Rated Power Input	1320	W
Cooling Minimum Power Input	260	W
Moisture removal at AHRI Cooling Rating Conditions	3.8	Pints/h
Sensible Heat Factor at AHRI Cooling Rating Conditions	0.76	-

Performance: Heating at 47F (8.3C)

Heating 47F Maximum Capacity	30200	Btu/h
Heating 47F Rated Capacity	17000	Btu/h
Heating 47F Minimum Capacity	5150	Btu/h
Heating 47F Maximum Power Input	2890	W
Heating 47F Rated Power Input	1390	W
Heating 47F Minimum Power Input	280	W
COP 47F at Rated Condition	3.58	

Performance: Heating at 17F (-8.3C)

Heating 17F Rated Capacity	12700	Btu/h
Heating 17F Minimum Capacity	4450	Btu/h
Heating 17F Maximum Power Input	3830	W
Heating 17F Rated Power Input	1240	W
Heating 17F Minimum Power Input	610	W
COP 17F at Maximum capacity	2.14	
COP 17F at Rated Condition	3	
Heating 17F Maximum Capacity	28200	Btu/h

Performance: Heating at 5F (-15C)

Heating 5F Maximum Capacity (H4Full)	23600	Btu/h
Heating 5F Rated Capacity (H4Full)	8080	Btu/h
Heating 5F Minimum Capacity (H4Full)	3730	Btu/h
Heating 5F Maximum Power Input (H4Full)	3350	W
Heating 5F Rated Power Input (H4Full)	790	W
COP 5F at Maximum capacity (H4Full)	2.06	
Heating 5F Minimum Power Input (H4Full)	530	W

Performance: Heating at -5F (-20.6C)

Heating -5F Maximum Capacity	19800	Btu/h
Heating -5F Minimum Capacity	3080	Btu/h
Heating -5F Maximum Power Input	2980	W
Heating -5F Minimum Power Input	480	W
COP -5F at Maximum Capacity	1.94	

Performance: Heating at -10F (-23.3C)

Heating -10F Minimum Capacity	2760	Btu/h
Heating -10F Maximum Power Input	2810	W
Heating -10F Minimum Power Input	440	W
Heating -10F Maximum Capacity	17500	Btu/h

Performance: Heating at -22F (-30C)

Heating -22F Maximum Capacity	9400	Btu/h
Heating -22F Minimum Capacity	1590	Btu/h
Heating -22F Maximum Power Input	1720	W
Heating -22F Minimum Power Input	270	W
COP -22F at Maximum Capacity	1.6	

ODU Operating Temp. Range

Cooling Thermal Re-start Temp	0	
Cooling Thermal Lock-out Temp	-4	
Heating Thermal Re-start Temp	-23	
Heating Thermal Lock-out Temp	-34	
Cooling Thermal Re-start Temp (C)	-17.8	C
Cooling Thermal Re-start Temp (F)	0 / -17.8	F° / C°
Cooling Thermal Lock-out Temp (C)	-20.1	C
Cooling Thermal Lock-out Temp (F)	-4 / -20	F° / C°
Heating Thermal Re-start Temp (C)	-30.3	C
Heating Thermal Re-start Temp (F)	-23 / -30.6	F° / C°
Heating Thermal Lock-out Temp (C)	-36.7	C
Heating Thermal Lock-out Temp (F)	-34 / -36.7	F° / C°

Rebates

Energy Star 6.1 Certified	Yes	
Energy Star 6.1 Cold Climate Certified	Yes	
NEEP Certification	Yes	

Efficiency

SEER2	25.5	
EER2	13.05	
HSPF2 (IV)	11.1	
HSPF2 (V)	10.6	

Electrical

Rated Voltage (Min)	208	V AC
Rated Voltage (Max)	230	V AC
Phase	1	
Short-circuit Current Rating (SCCR)	5	kA
Recommended Fuse/Breaker Size	25	
ODU Minimum Circuit Ampacity (MCA)	23	A
ODU Maximum Over Current Protection (MOCP) = MOP = Maximum Fuse	40	A
IDU Minimum Circuit Ampacity (MCA) if Powered Separate	1	A

Indoor Unit

IDU Airflow Rate at Cooling, Dry 1	272	CFM
IDU Airflow Rate at Cooling, Dry 2	339	CFM
IDU Airflow Rate at Cooling, Dry 3	392	CFM
IDU Airflow Rate at Cooling, Dry 4	456	CFM
IDU Airflow Rate at Cooling, Dry 5	593	CFM
IDU Airflow Rate at Cooling, Wet 1	231	CFM
IDU Airflow Rate at Cooling, Wet 2	288	CFM
IDU Airflow Rate at Cooling, Wet 3	333	CFM
IDU Airflow Rate at Cooling, Wet 4	387	CFM
IDU Airflow Rate at Cooling, Wet 5	504	CFM
IDU Airflow Rate at Heating 1	272	CFM
IDU Airflow Rate at Heating 2	311	CFM
IDU Airflow Rate at Heating 3	378	CFM
IDU Airflow Rate at Heating 4	456	CFM
IDU Airflow Rate at Heating 5	614	CFM
IDU SPL at Cooling 4	39	dB (A)
IDU SPL at Heating 5	47	dB (A)
Drain Pipe Size (Outer size)	10/16	inch
External Finish (Munsell No. in case painting)	Munsell 1.0Y 9.2/0.2	
IDU Unit Dimension D	9 3/4	inch
IDU Unit Dimension H	12	inch
IDU Unit Weight	31.4	lbs
IDU Unit Dimension W	39 5/16	inch

Outdoor Unit

ODU Fan Motor Full Load Amperage (FLA) (if data available)	0.76	A
ODU Fan Motor Output	0.1	HP
Base Pan Heater installed (Built-in or Optional)	Built-in	
ODU Unit Dimension W	33 1/16	inch
ODU Unit Dimension D	13	inch
ODU Unit Dimension H	34 5/8	inch
ODU Unit Weight	119.1	lbs

Piping

Gas Pipe Size O.D. [Flared]	1/2	inch
Liquid Pipe Size O.D. [Flared]	1/4	inch
Maximum Piping Length	100	ft
Maximum Height Difference	50	ft

Refrigerant

Refrigerant Type	R454B	
Pre-charged Refrigerant Amount	7	oz
Maximum Pre-charged Piping Length	50	ft
Pre-charged Refrigerant Amount (kg)	1.57	
Pre-charged Refrigerant Amount (lbs)	3	
Pre-charged Refrigerant Amount (oz)	7	

Accessories

Handheld Remote Controller English	MAC-FL110M-E	
Handheld Remote Controller French	MAC-FL210M-E	
Wall Mount controller	PAR-42MAACAB (REQUIRES SYSTEM INTERFACE)	
Simple Wall MA Controller	PAC-YT53CRAU-J	
Simple CN105 Controller	PAC-SDW01	
Deodorizing Filter	MAC-3010FT-E	
Microparticle Catching Filter	MAC-EMF515T-E	
Electrostatic Anti-allergy Enzyme Filter	MAC-2310FT-E	
System Interface (Full Control)	MAC-334IF-E	
System Interface (Functional Control)	MAC-497IF-E	
NA T-STAT interface	RMF-CA200	
NA T-STAT Interface	RMF-CA200	

AHRI Rated Conditions (Rated data is determined at a fixed compressor speed) (* Windscreens required for cooling operations below 23°F (-5°C))

- ¹ Cooling (Indoor // Outdoor) 80°F (26.6°C) DB, 67°F (19.4°C) WB // 95°F (35°C) DB, 75°F (23.9°C) WB
- ² Heating at 47°F (8.3°C) (Indoor // Outdoor) 70°F (21.1°C) DB, 60°F (15.6°C) WB // 47°F (8.3°C) DB, 43°F (6.1°C) WB
- ³ Heating at 17°F (-8.3°C) (Indoor // Outdoor) 70°F (21.1°C) DB, 60°F (15.6°C) WB // 17°F (-8.3°C) DB, 15°F (-9.4°C) WB
- tHeating at 5°F (-15°C) (Indoor // Outdoor) 70°F (21.1°C) DB, 60°F (15.6°C) WB // 5°F (-15°C) DB, 4°F (-15.6°C) WB
- uHeating at -4°F (-20°C) (Indoor // Outdoor) 70°F (21.1°C) DB, 60°F (15.6°C) WB // -4°F (-20°C) DB, -15°F (-26.1°C) WB

MSZ-FX18NL

Unit: inch

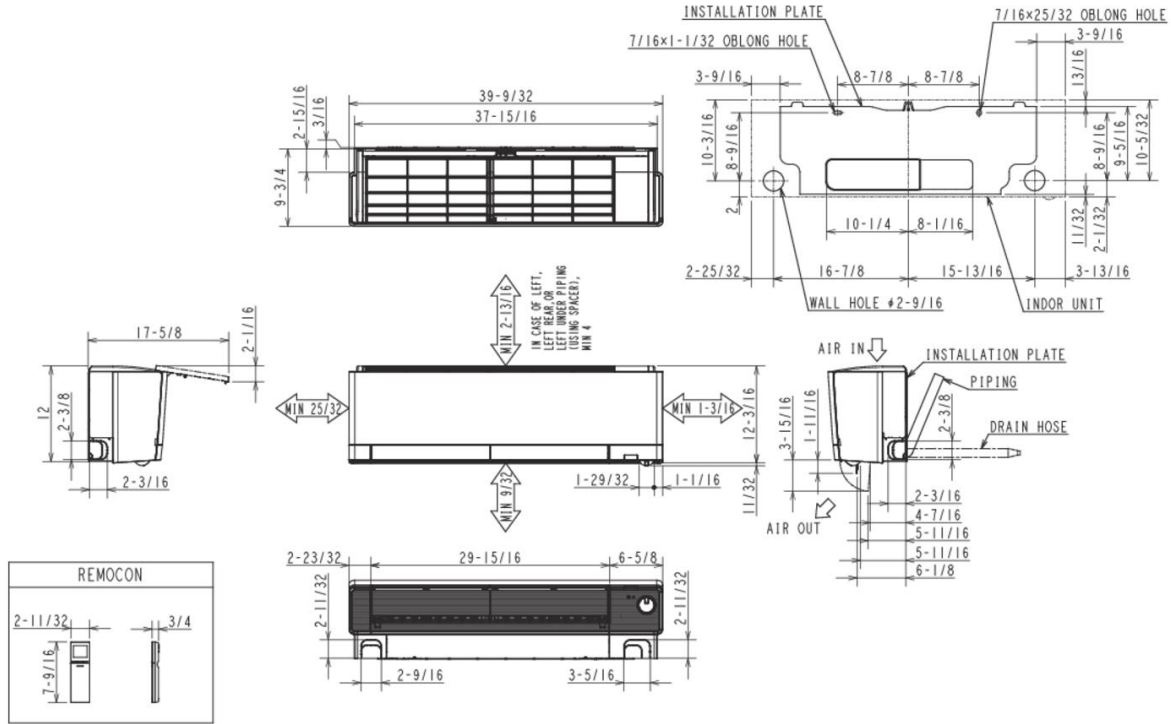

MSZ-FX06/09/12NL

PIPING	INSULATION	ø 1-9/16 O.D
	LIQUID LINE	ø 1/4 - 19-11/16 (FLARED CONNECTION ø 1/4)
	GAS LINE	ø 3/8 - 17-3/4 (FLARED CONNECTION ø 3/8)
DRAIN HOSE		INSULATION ø 1-5/32 CONNECTED PART ø 5/8 O.D

MSZ-FX24NL

PIPING	INSULATION	ø 1-9/16 O.D
	LIQUID LINE	ø 1/4 - 19-11/16 (FLARED CONNECTION ø 1/4)
	GAS LINE	ø 15/32 - 17-3/4* (FLARED CONNECTION ø 5/8)
DRAIN HOSE		INSULATION ø 1-5/32 CONNECTED PART ø 5/8 O.D

MSZ-FX15/18NL

PIPING	INSULATION	ø 1-9/16 O.D
	LIQUID LINE	ø 1/4 - 19-11/16 (FLARED CONNECTION ø 1/4)
	GAS LINE	ø 3/8 - 17-3/4 (FLARED CONNECTION ø 1/2)
DRAIN HOSE		INSULATION ø 1-5/32 CONNECTED PART ø 5/8 O.D

*The diameter of the gas line piping is ø 3/8 in one spot.

MUZ-FX18NLHZ2

Unit: inch

